

- ALUMINUM FACE, ALUMINIZED AND GALVANIZED STEEL DAMPER
- ADJUSTABLE CURVED BLADES
- MULTI-SHUTTER DAMPER
- MINIMUM SIZE = 6 X 6
- MAXIMUM SIZE = 14 X 8
- FINISH: WHITE (W) ENAMEL

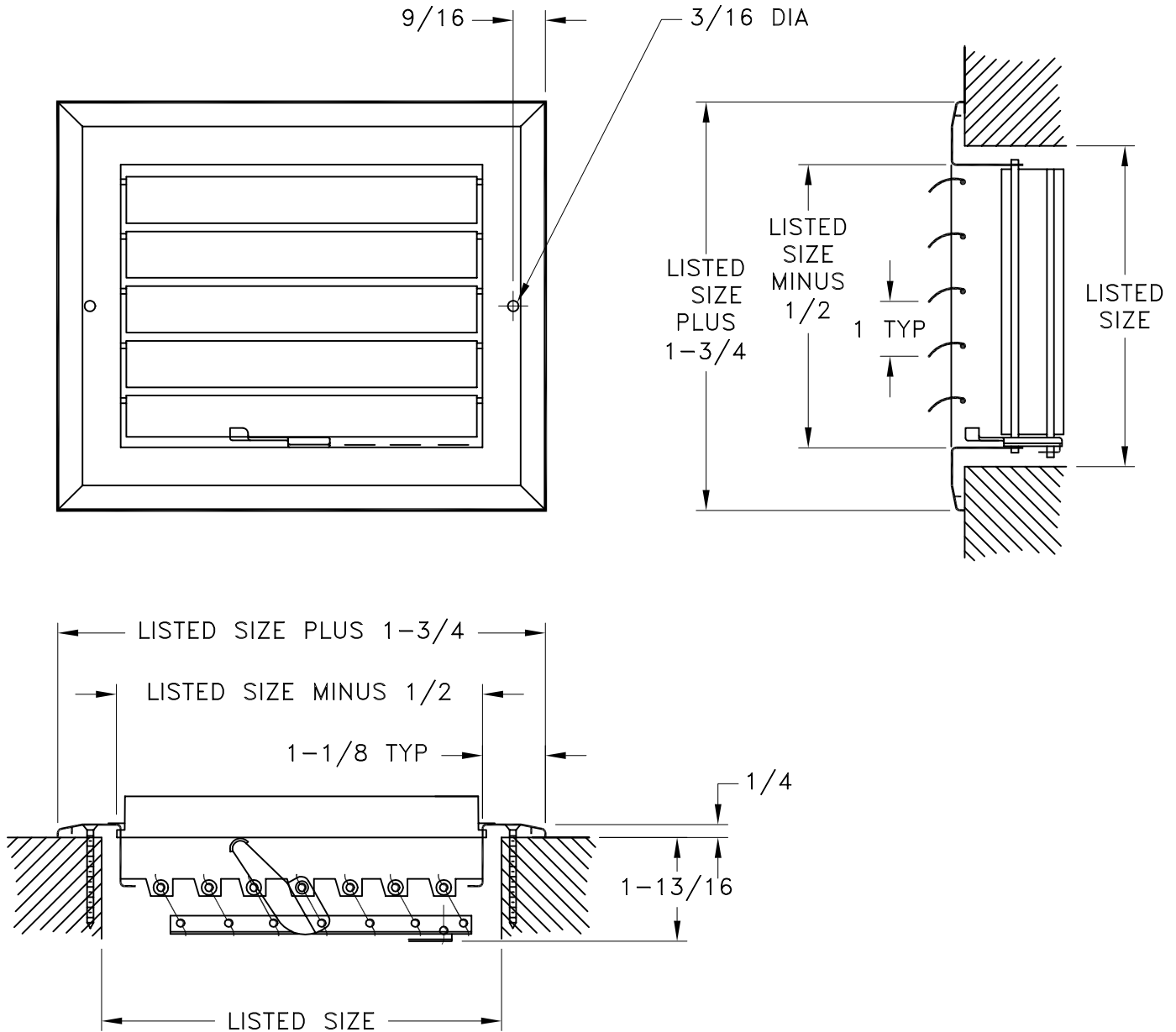

JOB NAME: _____	SUBMITTED BY: _____	DATE: 04/10/01	SD-2501
LOCATION: _____		A611MS Aluminum Curved Blade Register 1-Way Air Pattern	
ARCHITECT: _____			
ENGINEER: _____			
CONTRACTOR: _____			