



Hart & Cooley[®]
install confidence

**Light
Commercial
Grilles,
Registers &
Diffusers**

Edition 5

See
Inside
Front
Cover For
What's New...

LIGHT COMMERCIAL

Product Information Engineering Data

SPIRAL DIFFUSERS

SV	Single-Deflection Diffuser	.38	.99
SVH	Double-Deflection Diffuser	.38	.99
USV	Single-Deflection Universal Diffuser	.38	.99
USVH	Double-Deflection Universal Diffuser	.39	.99
SS	Linear Face Diffuser	.39	.97-98

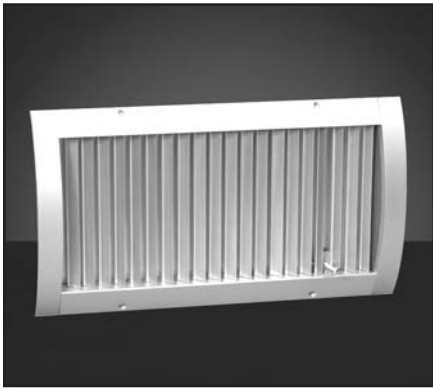

(Shown with scoop)
Size restrictions apply.
See price list for sizes and ordering information.

Model SV Single-Deflection Diffuser

- Extruded aluminum construction
- Single row of individually adjustable vertical blades for horizontal air-deflection control
- Available as diffuser only or diffuser with air scoop
- Optional face adjustable scoop to direct airflow
- Counter-sunk screw holes
- Available sizes: 10x3 to 36x12 for 6" to 36" ducts
- Bright White and Satin Anodized finishes

SV Available Sizes (in.) 10" x 3" to 36" x 12"
--

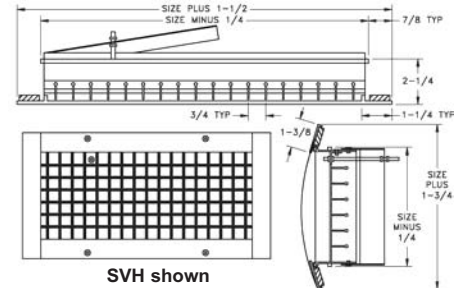

SVH shown



Size restrictions apply.
See price list for sizes and ordering information.

Model SVH Double-Deflection Diffuser

- Extruded aluminum construction
- Two rows of individually adjustable blades for horizontal and vertical deflection control
- Optional face adjustable scoop to direct airflow
- Counter-sunk screw holes
- Available sizes: 10x3 to 36x12 for 6" to 36" ducts
- Bright White and Satin Anodized finishes

SVH Available Sizes (in.) 10" x 3" to 36" x 12"

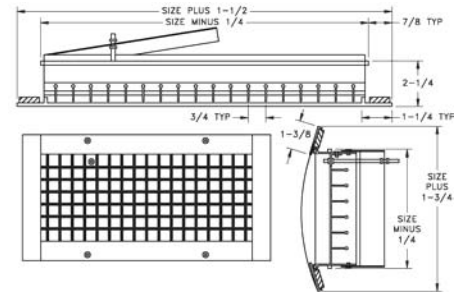

Size restrictions apply.
See price list for sizes and ordering information.

Model USV Single-Deflection Universal Diffuser

- Extruded aluminum construction
- Single row of individually adjustable vertical blades for horizontal air deflection control
- Optional face adjustable scoop to direct airflow
- Counter-sunk screw holes
- Available sizes: 10x3 to 36x12
- Fits duct sizes 6" on up, based on diffuser height
- Bright White and Satin Anodized finishes

USV Available Sizes (in.) 10" x 3" to 36" x 12"

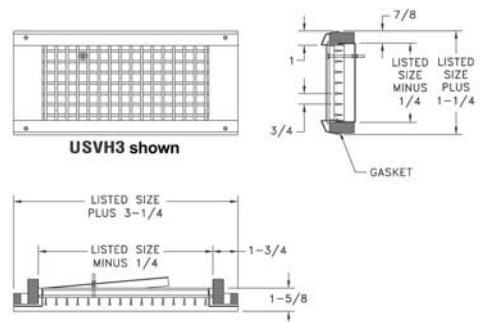

USVH3 shown

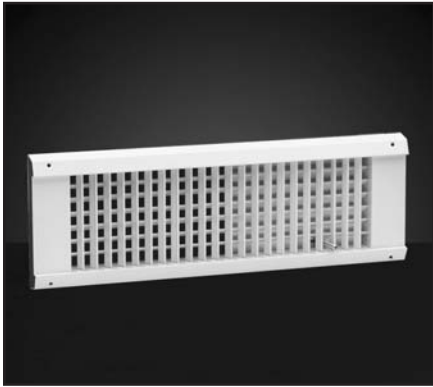

Size restrictions apply. See price list for sizes and ordering information.

Model USVH Double Deflection Universal Diffuser

- Extruded aluminum construction
- Two rows of individually adjustable blades for horizontal and vertical deflection control
- Optional face adjustable scoop to direct airflow
- Counter-sunk screw holes
- Available sizes: 10x3 to 36x12
- Fits duct sizes 6" on up, based on diffuser height
- Bright White and Satin Anodized finishes

USVH Available Sizes (in.) 10" x 3" to 36" x 12"

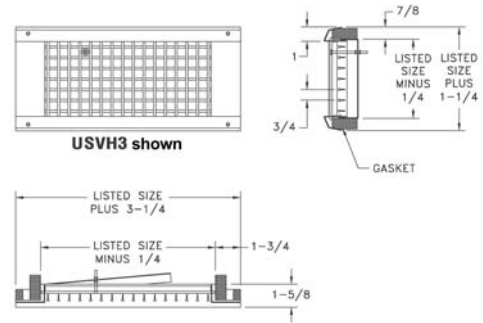

Size restrictions apply. See price list for sizes and ordering information.

Model SS Slot Face Diffuser

- Extruded aluminum construction
- Slot sizes available: 1/2", 3/4", 1"
- Optional face adjustable scoop to direct airflow. Scoop not available for 1/2" or 3/4" one slot
- Counter-sunk screw holes
- Available in one to four slots wide up to 48" length for 6" to 36" ducts
- Bright White and Satin Anodized finishes

SS Available Sizes (in.) One to four slots wide up to 48" long

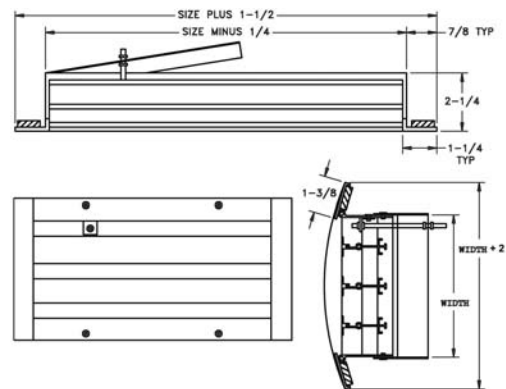

Slot Width	Width/Minimum Duct Diameter			
	Number of Slots			
	1	2	3	4
50 (1/2")	1.75/6	3.00/ 8	4.25/12	5.50/16
75 (3/4")	2.00/6	3.50/10	5.00/14	6.50/22
10 (1")	2.25/6	4.00/12	5.75/16	7.50/28

For Models SV and SVH
Minimum Duct Diameter per listed size

Height	Width								
	10	12	14	16	18	20	24	30	36
3	5	5	5	5	5	5	5	5	5
4	6	6	6	6	6	6	6	6	6
6	8	8	8	8	8	8	8	8	8
8	10	10	10	10	10	10	10	10	10
10		12	12	12	12	12	12	12	12
12			14	14	14	14	14	14	14

Maximum duct diameter for all sizes is 36".

For Models USV and USVH
Minimum Duct Diameter

Height	Width								
	10	12	14	16	18	20	24	30	36
3	6	6	6	6	6	6	6	6	6
4	10	10	10	10	10	10	10	10	10
6	12	12	12	12	12	12	12	12	12
8	20	20	20	20	20	20	20	20	20
10			24	24	24	24	24	24	24
12					30	30	30	30	30