

Hart & Cooley Oval Type B and BW Gas Vent Installation Instructions

Four and five inch oval B-vent are for venting listed gas appliances with draft hoods and other listed gas appliances specified for use with Type B Gas Vents. Except when four or five inch oval are used in 2 x 4 stud walls, both require a **1 INCH MINIMUM CLEARANCE TO COMBUSTIBLES.**

Four and five inch oval may be used in a 2 x 4 stud space with the proper clearance established by use of a OFS firestop spacer. Four inch oval has the same capacity as four inch round and five oval has the same capacity as five inch round.

Type BW Gas Vent is exclusively four inch oval vent combined with other parts for venting **ONLY** approved gas fired vented wall furnaces. Four inch oval vent has both Type B and Type BW markings on it.

Hart & Cooley Type B and Type BW are Underwriters' Laboratories tested and listed and intended for neutral or negative draft applications.

These installation instructions will enable the installer to make a safe and proper installation of the vent. Compliance with these instructions will insure an installation which will meet the requirements of all National Building Codes and the National Fuel Gas Code, NFPA No. 54 and NFPA No. 211. Hart & Cooley Type B and Type BW Gas Vents are listed under the follow-up Service of Underwriters' Laboratories, Inc.

FLUE GAS TEMPERATURE MUST NEVER EXCEED 550° F IN ANY HART & COOLEY GAS VENT SYSTEM.

HART & COOLEY OVAL B VENTS ARE NOT TO BE USED WITH APPLIANCES BURNING SOLID OR LIQUID FUELS.

Gas appliances which must be connected to chimneys

The following appliances must be connected to chimneys:

All incinerators in domestic applications.

All appliances which may be converted readily to the use of solid or liquid fuels.

Combination gas-oil burning appliances.

Unlisted appliances.

General instructions

The Vent should always be sized for the sea level name plate input rating of the appliance in accordance with the procedures set forth in the "Gas Vent Capacity Tables," in the Application Guide.

Provide for adequate air supply for combustion air and for draft-hood dilution air. Refer to NFPA 54 or the Application Guide for recommended arrangements and proper size of air supply openings.

Use only Hart & Cooley parts and fittings to insure an approved vent.

Portions of gas vents which may pass through accessible spaces must be enclosed to prevent personal contact with and possible damage to the vent.

Unenclosed outside vents are not allowed.

No damper or other restriction is permitted in a gas vent.

Single Wall Connectors:

In areas where local custom allows the use of single wall connectors and stove-pipe, these may be used with B-vent pipe with the considerations shown below. It must be pointed out that the use of single wall materials cause higher heat loss from the flue products which in turn reduce the draft and may cause condensation to occur.

(A) Since the heat loss from the single wall pipe is double that from B-vent pipe, be sure to use the capacity table for single wall connector.

(B) Observe the local requirements for clearance to combustibles for single wall pipe. This distance is six inches to nine inches in most areas.

(C) Do not run single wall connectors through unheated spaces, partitions, or in concealed areas.

Assembling joints

OVAL SIZES FOUR INCH and FIVE INCH

Use gloves when handling vent parts.

Slide the top pipe or fitting down over the upper end of the lower pipe until the tabs snap into the lower pipe. The joint will naturally come to a stop at this point if it is placed firmly down over the lower section.

If for some reason it is necessary to uncouple a joint, this may be easily done by using a screwdriver to loosen the tabs. The section can then be lifted off.

DO NOT USE SCREWS IN B-VENT SCREWS ARE NOT NECESSARY AND MAY CAUSE NOISE.

Step by Step Installation Procedure for Oval Type B Gas Vents

A typical installation of Oval Type B Gas Vent is shown in Figure 1.

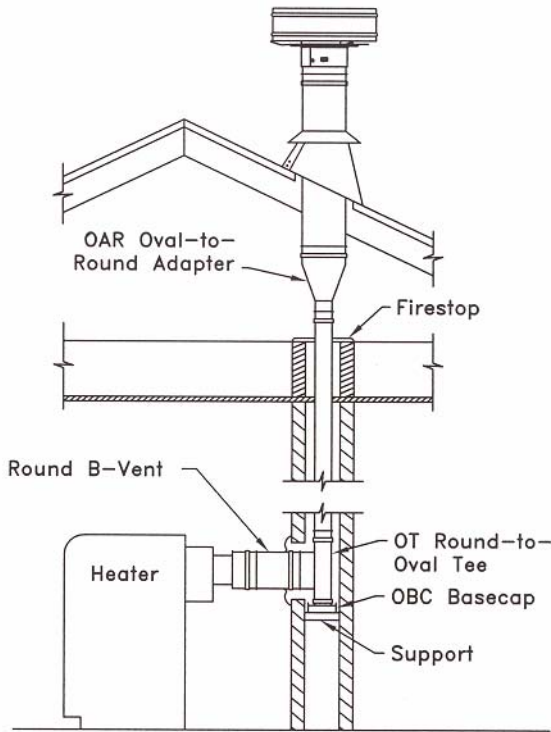

FIG. 1

An OBC base cap is fastened to the support and an OT (Oval Tee) locked to the base cap.

Sections of oval pipe are placed on top of the tee and carried through to the attic space with all joints being securely locked together. From this point on, an OAR oval-to-round adapter is used and the vent carried out with round pipe and fittings. **A MINIMUM CLEARANCE OF**

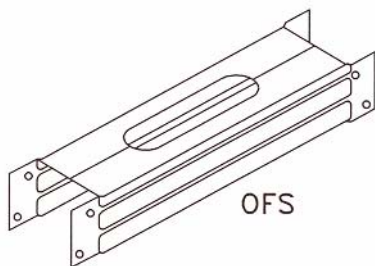

FIG. 2

ONE INCH TO COMBUSTIBLE CONSTRUCTION must be maintained throughout all portions of the vent, except in the stud space.

Firestopping

To firestop a stud space, the ceiling plate is cut completely away between studs and the OFS firestop spacer nailed in place (See Figure 2)

In many instances, vents pass through ceilings which are insulated. In these cases, it is necessary to frame around the opening in the ceiling for passage of the vent pipe so

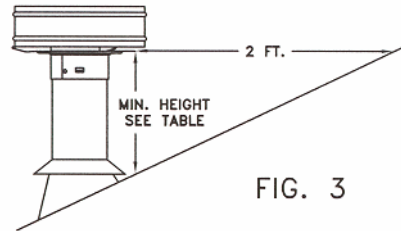

FIG. 3

that building insulation or other combustible material will not come in contact with the surface of the vent.

In multi-story buildings, a firestop must be provided at every point where the vent passes through a floor or ceiling. These firestops may be provided as indicated in the paragraph above.

Terminations using a flashing and cap assembly

General Instructions

Model RHW caps are listed for installation on gas vents terminating a sufficient distance from the roof so that no discharge opening is less than two feet horizontally from the roof surface. The lowest discharge opening shall be no closer than the minimum height shown in Table 1 and Figure 3. These minimum heights may be used provided that the vent is not less than eight feet from any vertical wall.

If a vent extends more than five feet above the roof, it should be guyed with three wires or braced with two pieces or rigid conduit.

Table 1

Roof Pitch	Minimum Height from Roof to Lowest Discharge Opening (Feet)
Flat to 7/12	1.0
Over 7/12 to 8/12	1.5
Over 8/12 to 9/12	2.0
Over 9/12 to 10/12	2.5
Over 10/12 to 11/12	3.25
Over 11/12 to 12/12	4.0
Over 12/12 to 14/12	5.0
Over 14/12 to 16/12	6.0
Over 16/12 to 18/12	7.0
Over 18/12 to 20/12	7.5
Over 20/12 to 21/12	8.0

CAUTION

WHERE HEAVY SNOWFALL OCCURS, THE CAP SHOULD BE INSTALLED TO A HEIGHT ABOVE THE AVERAGE SNOW DEPTH.

WHERE THE VENT PASSES THROUGH THE ROOF, the roof sheathing should be cut away sufficiently to **PROVIDE A MINIMUM OF ONE INCH CLEARANCE** from the vent pipe. The vent pipe should be run up to a point where the top end is at least one foot or so above the roof. Then, an RF roof flashing should be placed down over the upper end of the pipe and adjusted so the base plate of the flashing fits tightly against the roof with the vent pipe held in a position **MAINTAINING THE ONE INCH CLEARANCE FROM COMBUSTIBLE CONSTRUCTION.**

The flashing may then be fastened to the roof. The RS storm collar should be placed immediately above the roof flashing. Seal the storm collar with RTV silicone to the vent pipe.

Step by Step Installation Procedure for Oval Type BW Gas Vent

General Instructions

Type "BW" vent is four inch oval B-vent. For single story installation, the maximum wall heater input must not be greater than 85,000 BTU. For multi-story installation, the maximum wall heater input must not be greater than 65,000 BTU.

Type "BW" gas vents are listed for use with approved vented gas fired wall furnaces only.

Terminate Type "BW" vents at least 12 feet in vertical height above the bottom of the heater.

The stud space in which the vent is installed is to be ventilated at the first ceiling level penetrated by the vent by installing an OCP Ceiling Plate Spacer. The firestop spacer OFS must be used at each subsequent ceiling or floor level penetrated by the vent.

Use sufficient oval vent to extend at least six inches into the attic and continue through the roof with round vent and flashing accessories.

Erection of the Type BW Gas Vent

The stud space in which the vent is located should be 3-1/2 inches x 14 -3/8 inches inside dimensions, or larger.

In new construction after the location of the recessed heater has been determined, the heater plate supplied by the manufacturer of the heater is mounted in the stud space at the proper height as specified in the manufacturer's instructions, and serves as the firestop at that point. (See Figure 4).

The OBP base plate is fastened to the header plate with sheet metal screws, making sure that the seal is properly made between the base plate and header plate.

The ceiling plate is next cut completely away between studs and one of the OCP ceiling plate spacers nailed in

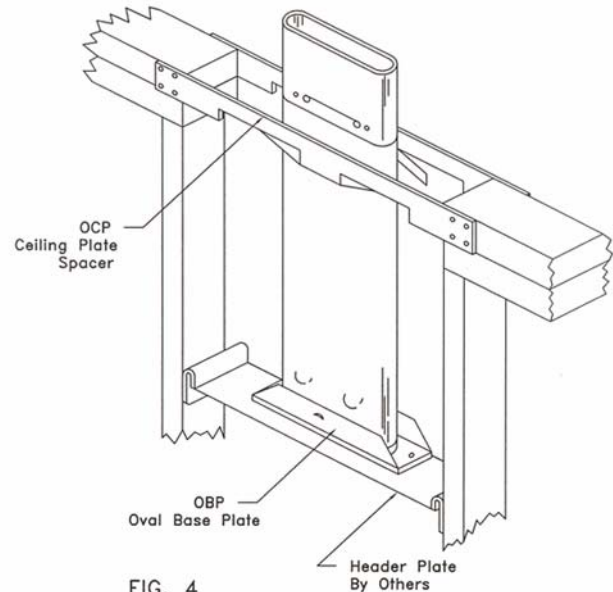

FIG. 4

place as shown in Figure 4.

A section of oval pipe of sufficient length to extend above the ceiling plate level is put in place and locked to the base plate, again making certain that the seal between the vent pipe section and the base plate is properly made

The second ceiling plate spacer is next put into place, and the tabs adjusted to center the oval vent section in the stud space. Means, such as framing or a sheet metal sleeve, should be provided around the top of the opening to insure that insulation or other material does not fall down into, nor reduce the opening of, the ventilated stud space. For multi-story installations, a 40FS firestop spacer is required at each subsequent floor and ceiling.

An OAR oval-to-round adapter is used to convert to round pipe before going through the roof. **ONE INCH MINIMUM CLEARANCE TO COMBUSTIBLES MUST BE MAINTAINED** from the vent at all points above the ceiling plate level. The vent may either be run straight out through the roof or be offset in the attic and follow the roof line to a point near the peak before piercing the roof. Round pipe and elbows are used in making the offset and should be securely supported by metal straps.

Miscellaneous Applications

Vents in Furred-Out Spaces and Partitions

It is required to enclose Type B Vents which extend through accessible spaces to prevent personal and material contact with and damage to the vent. They may be run through furred-out spaces or partitions in which case the framing must be arranged so that one inch minimum clearance from combustible construction can be maintained. Examples of furred-out spaces and partitions are shown in Figures 5 and 6.

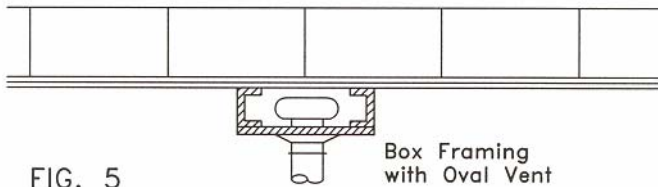

FIG. 5

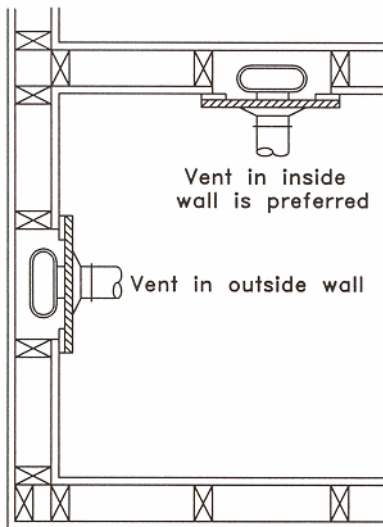

FIG. 6

Notice Concerning Limitation of B-vent Pipe to Use with Gas Appliances

In those sections of the country where solid and liquid fuels are used extensively, gas vent system shall be plainly and permanently labeled: *"This gas vent is for appliances which burn gas only. Do not connect to incinerators or solid or liquid fuel burning appliances."*

The authority having jurisdiction shall determine whether the particular locality constitutes an area where such notice must be posted.

In those cases where the posting of such a notice is required, a label shall be placed as follows:

(A) Where a vertical vent is used, the label shall be placed on the ceiling near the point where the vent passes through the ceiling.

(B) If the vent has a vent connector, the label shall be placed on the wall near the point where the vent connector passes through the wall, on the side of the partition on which the appliance is located.

THESE INSTRUCTIONS SHOULD REMAIN AVAILABLE TO THE HOMEOWNER



Hart & Cooley
install confidence

Hart & Cooley, Inc.
500 East Eighth Street
Holland, MI 49423
info@hartcool.com
www.hartandcooley.com

800.433.6341 *toll-free*
616.392.7855 *phone*
800.223.8461 *toll-free fax*
616.392.7971 *fax*