

Installation and Maintenance Instructions

Model SW

Single Wall

AL 29-4C Stainless Steel

Gas Vent Connector

Chimney Liner &

Special Gas Vent (USA) / Type BH Vent Class I/II (Canada)

For Venting Residential, Commercial & Industrial Appliances
Category I, II, III & IV Appliances

3"-5" Diameter Vent for use on Positive, Neutral and Negative
Pressures up to 9" W.C.

Important: Do NOT install this product until you have read and fully understand these installation instructions. Failure to comply with these instructions may result in injury or damage to property. An improper installation will void any stated warranty.

- Follow these instructions exactly as written.
- Examine all components for possible shipping damage prior to installation.
- Proper joint assembly is essential for a safe installation. Check integrity of joints upon completion of assembly.
- This venting system must be supported in accordance with these instructions.
- Check for restricted vent movement through the walls, ceilings and roof penetrations. This venting system must be free to expand and contract.
- Do not mix SW vent pipe with pipe from different manufacturers.



Tested and Listed to
UL1738 & ULC S636
By Underwriters Laboratories, Inc.

WARNING

Failure to follow the installation instructions could cause FIRE, CARBON MONOXIDE POISONING, OR DEATH. If you are unsure of installation requirements, call the phone number listed on the back page of these instructions.

Model SW Special Gas Vent Systems may be used to vent safety certified Category I, II, III, IV and Certain Direct Vent gas appliances with a flue gas temperature of not more than 550° F (288° C). The Model SW system is for use with appliances which produce positive vent pressures of 9 inches of water column or less. Because these types of appliances may produce vent gases under positive pressure and/or at or near their dew point, special installation considerations may be required.

Install in accordance with these instructions and those of the appliance manufacturer. Consult the appliance manufacturer's instructions for the maximum horizontal length of the vent connector as well as any restriction on total vent height, proper sizing of the vent, common venting considerations and procedures for connecting the vent to the appliance.

The installation must conform to applicable National, Regional, State and local codes. Contact the Authority Having Jurisdiction prior to beginning any work to obtain any required permits.

Pre-Installation Considerations:

Proper planning prior to installation is essential for maintaining proper clearances and for avoiding possible contact with concealed plumbing or electrical wiring inside walls, floors and ceilings. A continuous straight-line pitch of at least 1/4 inch (2 degrees) rise per foot on horizontal runs must be maintained in order to properly rid the system of the corrosive condensate. Be sure to plan a sufficient number of supports for the entire system to maintain the required straight-line pitch and to hold the system in place. Where the vent is enclosed within a chase, the enclosures should be built to permit future inspection of the system.

Personal Safety

Wear eye protection and heavy gloves throughout the installation. In addition, wear an approved dust and vapor respirator whenever in contact with building insulation. Proper and safe scaffolding and/or ladders should be used. Check overhead for antennas, power lines or other obstacles before erecting ladders or scaffolding and while working with conduit on any roof structure.

Tools Required for Installation

Common building tools including but not limited to a Tape Measure, Pliers, Screw Drivers, Saws and/or Snips, Drills, Drop Cloth(s); Ladder/Scaffold; Safety and Personal Protective Clothing.

Definitions:

AL 29-4C - A super ferritic stainless steel alloy designed by Allegheny Ludlum for extreme resistance to chloride ion pitting, crevice corrosion and stress corrosion cracking. Equivalent material made by other manufacturers may be identified by the UNS designator S44735.

Category I Appliance - An appliance which operates with a non-positive vent static pressure and with a vent gas temperature that avoids excessive condensate production in the appliance.

Category II Appliance - An appliance which operates with a non-positive vent static pressure and with a vent gas temperature that may cause excessive condensate production in the appliance.

Category III Appliance - An appliance that operates with a positive vent static pressure and with a vent gas temperature that avoids excessive condensate production in the appliance.

Category IV Appliance - An appliance that operates with a positive vent static pressure and with a vent gas temperature that may cause excessive condensate production in the appliance.

Combustible Material - Any material made of or surfaced with wood, compressed paper, plant fibers, or other materials that are capable of being ignited or burned. Such material shall be considered combustible even though it is flame proofed, fire-retardant treated, or plastered. (Source: NFPA54/ ANSI Z223.1-2006.).

Clearance to Combustibles and Framing Requirements

Table 1 shows the required MINIMUM AIRSPACE CLEARANCE TO COMBUSTIBLES. "Combustibles" include framing lumber, drywall, plywood, paneling, insulation, wiring and other building materials. This airspace clearance is required for safe operation of the vent. Failure to follow these clearances could overheat the building materials and could cause fire.

Pipe Size	Max Appliance Flue Gas Temperature	Minimum Clearance			
		Enclosed Vent		Unenclosed Vent	
		Vertical	Horizontal	Vertical	Horizontal
3" & 4"	480°F	4"	8"	1"	1"
3" & 4"	550°F	4"	N/A	1"	1"
5"	400°F	4"	N/A	1"	1"
	480°F	5"	N/A	1"	1"
	550°F	6"	N/A	1"	1"

Table 1. Minimum Clearance to Combustibles

Note: 5" Vent is NOT to be installed horizontally in a fully enclosed combustible enclosure.

Vertical (Floor, Ceiling and Roof) Penetrations

Where the vent passes through a floor, ceiling or roof the hole size or framing dimension must maintain minimum clearances per Table 1. Floor and Ceiling penetrations require a Fire Stop (by others) to be installed. See Fire Stop section for installation instructions.

Horizontal (Wall) Penetrations

All horizontal systems passing through a combustible wall require the use of a Wall Thimble. See Table 2 for proper framing dimensions and refer to Wall Thimble section for installation instructions. Non-combustible wall penetrations do not require a Wall Thimble.

Pipe Size	Minimum Framing Dimensions
	Wall Thimble
3"	6.5" x 6.5"
4"	6.5" x 6.5"
5"	10" x 10"

Table 2. (Minimum Framing Dimension)

TYPICAL INSTALLATION CONFIGURATIONS

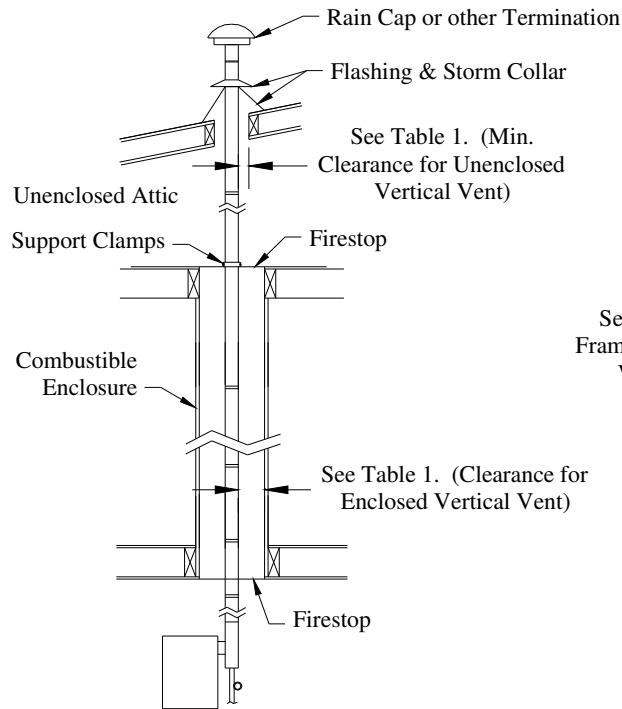

Fig 1. (Vertical Termination)

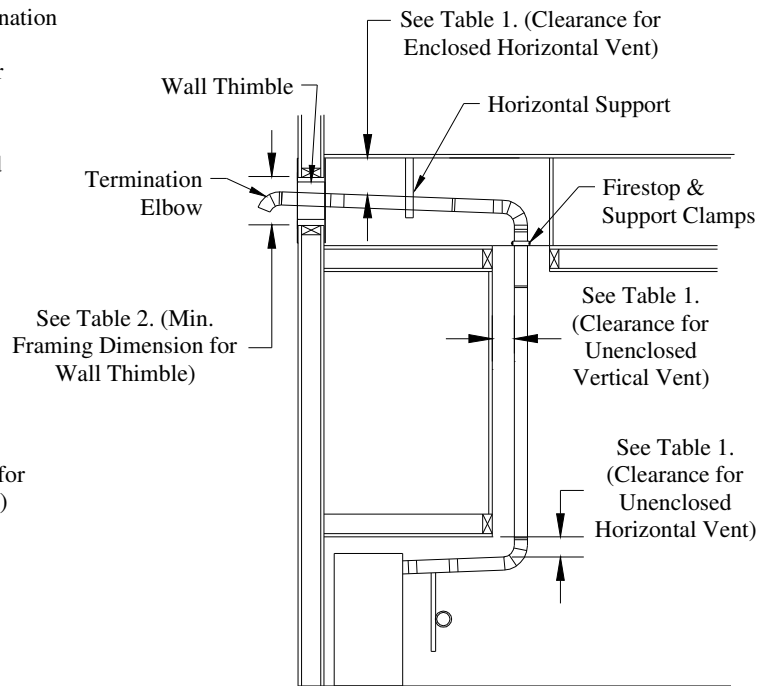

Fig 2. (Horizontal Termination)

In addition to the configurations shown in Figs. 1 & 2, this system may be installed in any combination of vertical and horizontal, enclosed and unenclosed configurations as long as minimum clearances are maintained per clearance Tables 1 & 2 and the total length and number of fittings does not exceed the appliance manufacturer's recommendations. This system may also be installed within an existing masonry chimney.

Notes:

1. Unenclosed systems require at least one side open (combustible material on maximum of 3 sides).
2. Reduced clearances may be attained by using noncombustible enclosures.
3. Do not place insulation in any required clearance spaces surrounding the vent system unless these instructions suggest otherwise and the insulation is specified or supplied.

VENT ROUTING LIMITATIONS - MAXIMUM EQUIVALENT LENGTHS

In order to insure the vent system is not overly restrictive to flow, refer to the maximum length of vent specified by the appliance manufacturer. In order to account for turns in the system (which cause additional resistance to flow) most manufacturers recommend using an "Equivalent Length" method of determining the limitations. Via such method, elbows and tees are assigned an "equivalent length" (in feet). If the sum of straight length segments and additional "equivalent lengths" (due to turns) exceeds the limit specified by the manufacturer, the routing is not permitted. See appliance manufacturer's instructions for additional information.

If the appliance manufacturer's instructions do not list equivalent lengths for standard fittings, use Table 3 to determine the Equivalent Length of the vent fittings.

Equivalent Length Table	
Fitting	Equivalent Length
Straight Length	1' per 1'
Boot Tee	10'
90 Degree Elbow	10'
70 Degree Elbow	8'
45 Degree Elbow	5'
30 Degree Elbow	4'
15 Degree Elbow	3'

Table 3

GENERAL INSTALLATION REQUIREMENTS

1. In instances where the appliance manufacturer's instructions conflict with requirements in this document, the appliance manufacturer's instructions take precedence.
2. Failure to conform to any of these requirements may violate local, state or national codes as well as create conditions which may cause catastrophic property damage and/or personal injury.
3. The horizontal vent connector must slope continuously toward an appliance drain, a drain fitting or tee, or the termination. The vent must be pitched at least 1/4 inch per foot so that any condensate is not retained in any part of the venting system.
4. If called for by the appliance manufacturer's instructions, a drain fitting must be located as close as possible to the appliance flue outlet. Additional drains are required for each 30' of vent. If a drain fitting is not supplied with the appliance, install a SW in-line drain or a tee with a drain tee cover. Properly dispose of collected condensate.
5. Multiple Category III or IV appliances may not be interconnected to any part of the venting system unless the appliance manufacturer has specifically approved the engineering of the vent system. A Category III or IV appliance may not be interconnected to any part of a vent system used with a natural draft or draft hood appliance, except when a listed mechanical draft system is installed.
6. For venting systems that extend through any zone above that on which the connected appliance is located (except for one and two family dwellings), codes require that the vent system be enclosed with an enclosure having a fire resistance rating equal to or greater than that of the floor or roof assemblies through which it passes. In one and two family residential construction the system must be enclosed whenever passing through occupied spaces. The enclosure should be fabricated to allow periodic inspection of the vent.
7. Whenever gas-burning equipment is installed in the same space where halogenated substances may exist (refrigerants, solvents, bleaches, salts, etc.), clean outside air must be utilized for combustion.
8. When passing 5' or more of vent through an unheated area (such as attics, crawl spaces, building exteriors or above roof lines), it is recommended that the system be converted to double wall CI Plus (or CV for 3" and 4" pipe) to prevent condensation and freezing. Any penetrations of ceilings, floors, or walls must be properly fire-stopped.
9. The vent system shall not be routed into, through or within any other actively used vent or chimney.
10. Another appliance may not vent into the flue space outside the SW conduit. However, if there is sufficient space and all manufacturer's instructions and codes are followed, a separate chimney liner may be installed within the chimney to vent another appliance.

HORIZONTAL INSTALLATION REQUIREMENTS

1. If the termination is through a combustible wall, the system must terminate with a SW Wall Thimble and a SW termination as required by the appliance manufacturer.
2. The horizontal termination shall be located not less than 12 inches above grade or anticipated snow line (remember to consider snow and ice falling from overhead objects), and not less than 7 feet above grade when located adjacent to a public walkway. It shall also terminate a minimum of 4 feet below, 4 feet horizontally from, or 1 foot above any door, window, fresh air intake, utility meter or regulator unless the appliance is Listed differently. The termination must be a minimum of 6 feet from the combustion air intake of any other appliance. Proper judgment may require greater distances depending on the size of the equipment installed or site conditions. Consult with the local Authority Having Jurisdiction.
3. The termination should be away from trees, shrubs, or decorative items as flue gases could cause damage.
4. The total equivalent horizontal distance of the vent system from the appliance flue collar to the termination shall not be less than 14 inches.
5. A minimum of one (1) horizontal support is required for every 6 feet of run.

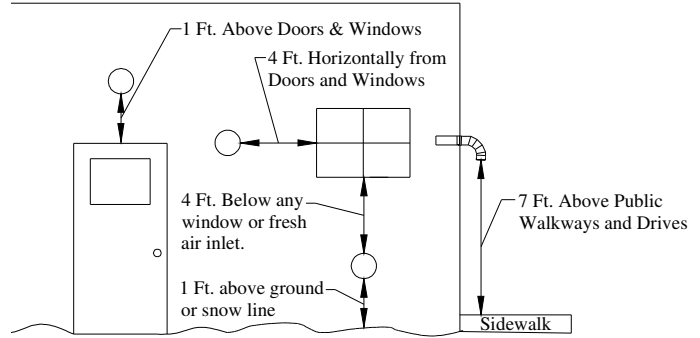

Fig 3. (Horizontal Installation Requirements)

VERTICAL INSTALLATION REQUIREMENTS

1. The vent system must terminate at least 3 feet above the roof line and at least 2 feet higher than any portion of the building within 10 feet.
2. When terminated at a height of more than 6 feet above the roof, the vent must be supported by a SW Guy Section. Refer to the Guy Support section of these installation instructions.
3. The vent system must terminate with one of the Terminations; except when a Termination or approved mechanical vent device is specified or provided by the appliance manufacture.
4. The total continuous distance of the vent system from the appliance flue collar to the termination shall not exceed that specified in the appliance manufacturer’s installation instructions. When venting natural draft appliances the termination must be at least 5 feet above the topmost draft hood. Otherwise a Listed mechanical draft inducing device is required.
5. Vertical supports are required after every transition to vertical and as specified in Table 4. Vertical supports are also required above every offset elbow. See Table 4 for vertical support limits.

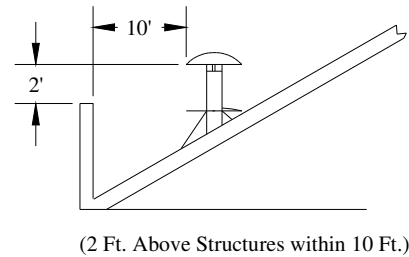

Fig 4. (Vertical Installation Requirements)

JOINT SEALING AND CONNECTION METHOD

Model SW (Diameters 3" thru 16") is manufactured with a factory installed seal on the inside of the female (outlet) end making the use of any additional sealant unnecessary.

Connection

Note: When provided, apply 7001SIL-5 lubricant to the seal to improve ease of installation before connecting parts.

1. Connect parts using the Ring and Tab Connection Method. See Fig 5.
 - a. To connect, slide the lock ring away from the end to allow clearance for the tabs extending from the female end.

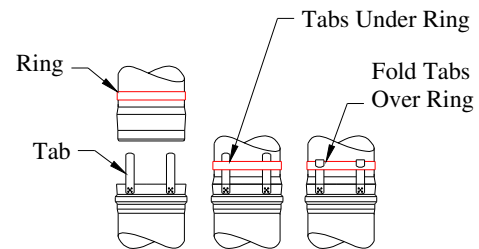

Fig 5. (Ring and Tab Connection)

- b. Engage the two sections making sure the tabs stay to the outside of the vent.
- c. After the sections are fully engaged, slide the lock ring down over the tabs, making sure all tabs are contained within the lock ring.
- d. Bend the tabs back over the lock ring to complete the joint. Note: Some termination parts have a hose clamp in place of the lock ring. In such cases, the hose clamp is tightened down over the tabs. The tabs need not be bent over the clamp.

Condensate Drains:

When An Internal Condensate Drain Is NOT Part of the Appliance:

- A SW In-Line Drain Section, Tee or Boot Tee with a separate Tee Cover Drain is strongly recommended. Install this drain fitting as close to the appliance flue collar as possible (See Fig. 6A).
- Use the Boot Tee to transition from horizontal to vertical and attach the Drain Tee Cover to the appropriate leg of the tee (See Fig 6A).
- A condensate drain is required for every 30 feet of horizontal vent and at/near the bottom of a vertical stack.
- Use the In-Line Drain Section for a straight horizontal run. Rotate the fitting so that the drain tube points downward and is as vertical as possible (See Fig. 6B).
- A Condensate Drain Tube Kit is available to drain the condensate to an appropriate location (i.e. floor drain or vented sanitary sewer connection). A trap loop must be formed into the drain hose and must be a diameter that is at least four times the appliance's rated stack pressure in inches of water column or 3 inches, whichever is greater. Secure the loop with a cable tie. Prior to final assembly the trap loop must be 'primed' by pouring a small quantity of water into the drain hose.
- Follow all local and national codes and regulations for the draining of acidic condensate.
- In cold climates do not install a condensate drain on the exterior of the building. Doing so may result in dangerous icy conditions on surfaces near the drain and may cause damage to the vent system and/ or the building exterior. Hart & Cooley will **NOT** be held liable for any injury or property damage due to formation of ice.

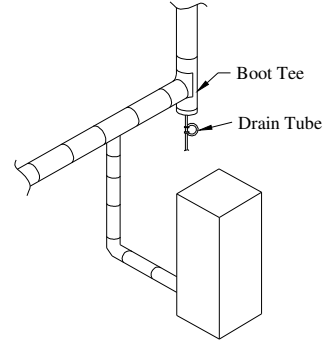

Fig 6A. (Boot Tee w/ Drain Cover & Tube)

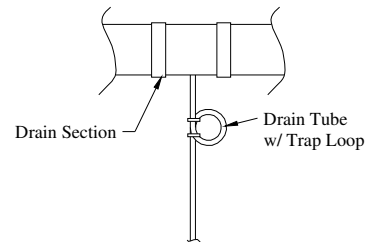

Fig 6B. (In-Line Drain Section and Drain Tube)

Adjustable Section:

The SW Adjustable Length Section serves as a variable length between other components when specific lengths cannot be utilized and eliminates the need to cut parts to length. To install, refer to installation instructions included with the Adjustable length.

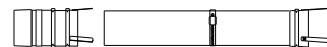

Fig 7. (Adjustable Length)

Customized Lengths— Cutting Standard Lengths

The SW system is designed so that in most cases standard lengths will not need to be cut. There may arise, however, an occasional situation where standard lengths and adjustable length slip connectors are not adequate. In such cases, a standard length of SW vent may be field cut.

To custom cut a standard length part:

1. Measure the length of vent needed (Dim A) and add 3 inches to the result.
2. Measuring from the female end (end with the tabs) measure out the distance $A + 3"$ and mark it on the pipe.

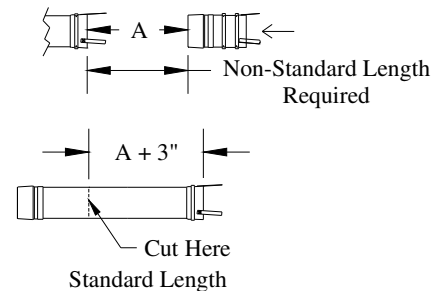

Fig 8. (Cutting Standard Lengths)

- Cut the pipe with an abrasive cutoff, plasma, or compound snips.

To help get a square cut, create a straightedge by wrapping masking tape around the waste side of the cut point. If using snips, start the cut at the male end and follow a spiral path around the pipe until the cutoff mark is reached.

- File off any burrs that develop in the cutting process prior to assembling. If the cutting process distorts the roundness of the pipe carefully use your thumbs to re-round the end.
- Apply high-temperature silicone sealant to the field-cut joint.
- Assemble the joint using the procedures above.
- A hose clamp must be used to retain the tabs.

Spacing Between Supports		
Diameters	Vertical Spacing	Horizontal Spacing
3" thru 5"	30'	Every six (6) feet and after every transition from vertical to horizontal.

Table 4. (Vertical and Horizontal Support Requirements)

Vertical and Horizontal Support

For proper installation, Vertical and/or Horizontal supports must be installed to support the SW vent. Refer to Table 4 for minimum spacing distances and the corresponding section for instructions for installing the support. Note: For all support options, ensure all minimum clearance to combustibles are maintained. Never drill or screw through the SW system.

Guy Support Section

The Guy Support is a short section of vent pipe with brackets protruding from it. These brackets provide a means for attaching a guy line, threaded rod or similar metal bracing to provide support to the vent system.

To Install: Connect Guy Section to the vent using standard joint connection method. Attach guy wires or metal bracing to the brackets provided on the Guy Section. Anchor guy wires or bracing to the building infrastructure capable of supporting the load of the vent (See Fig. 9).

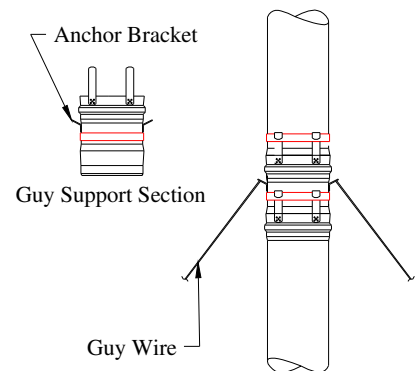

Fig 9. (Guy Support Assembly)

Fire Stop (by others)

Wherever the vent passes through a ceiling or floor a metal Fire Stop must be installed. To Install: Establish the correct framing dimension (See Table 1) and nail the Fire Stop to the joist. Route the vent through the Fire Stop plate. Caution about insulation in attics – Note: When installing a Fire Stop in the attic, the Fire Stop should be located on the top of the joist to prevent insulation from falling into the joist. **Keep all attic insulation the proper minimum clearance from pipe** by installing an enclosure or similar around the pipe.

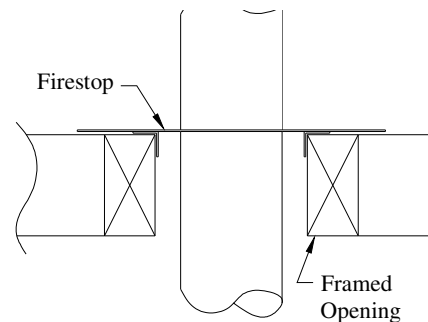

Fig 10. (Firestop)

Support Clamps

Support Clamps may be suspended from rods or cables and used as a saddle to rest the vent in or they may be used in pairs to clamp around the vent and suspended from a single rod, cable or fire stop (See Fig. 11).

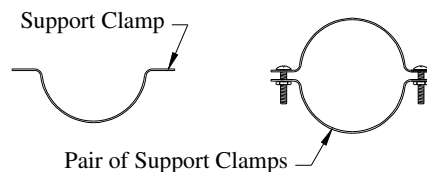

Fig 11. (Support Clamps)

2" Clearance Horizontal Support

The 2" Clearance Horizontal Support provides horizontal support for the vent and maintains a minimum of 2" of clearance to the wall. To install: Secure the mounting plate to the wall by installing fasteners through the pilot holes in the mounting plate, and into the wall. Install a pair of Support Clamps around the vent, and secure the Support Clamp to the Horizontal support by installing a bolt through the mounting tabs on the Support Clamps and through the pilot hole in the 2" Horizontal Support (See Fig. 12).

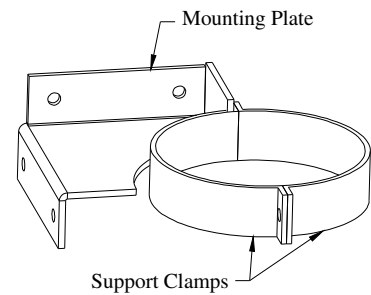

Fig 12. (2" Clearance Support)

1" Clearance Support

The 1" Clearance Support provides horizontal and/or vertical support for the vent and maintains a minimum of 1" air clearance. To Install: Secure the 1" Clearance Support to the wall or ceiling by installing screws through the mounting plate and into the mounting surface. Route the vent through the adjustable clamps and secure by tightening the Worm Gears (See Fig. 13).

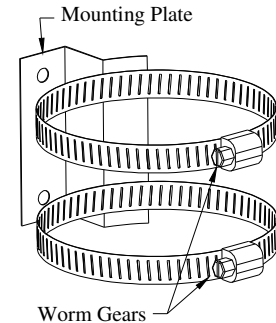

Fig 13. (1" Clearance Support)

Flashings

The flashing should be installed where the vent pipe passes through a roof and is used to seal the opening in the roof from the outside. The flashing should be located so that the vent is vertical and proper clearance is maintained as the vent passes through the roof. The Tall Cone Flashing is used on flat roofs only. Once located, each corner of the base flange should be nailed to the roof.

The Adjustable Roof Flashing is for pitched roofs. The low end portion of the base should be installed on top of the roofing material. The upper end of the flashing base should be nailed to the roof and roofing material should cover over the upper part and sides of the flashing base (See Fig. 14).

Storm Collar

The Storm Collar is designed to shed rain away from the flashing opening. To install, place the Storm Collar over the last segment of vent and slide it down to where it contacts the flashing. Depending on the type of storm collar you have, tighten the worm gear or the bolts on the tab to secure the Storm Collar to the vent. Apply silicone sealant over the joint between the vent pipe and the Storm Collar (see Fig. 14).

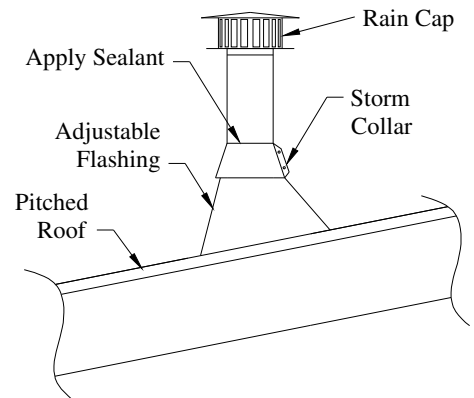

Fig 14. (Flashing, Storm Collar & Cap)

Rain Cap

The Rain Cap terminates the vent system and prevents rain from entering the vent. Refer to Vertical Termination Requirements section for guidelines for locating the Rain Cap. To Install: Once the proper height and clearance is established, the Rain Cap connects to the vent pipe via standard Ring and Tab connection method. Refer to Joint and Connection Section for instructions on proper joint connection method (See Fig. 14).

Wall Thimble

The Wall Thimble is used for passing the vent through combustible interior or exterior walls (See Fig. 15).

To Install:

1. Prepare a square or round opening in the wall. Refer to Table 2 to for proper hole size.

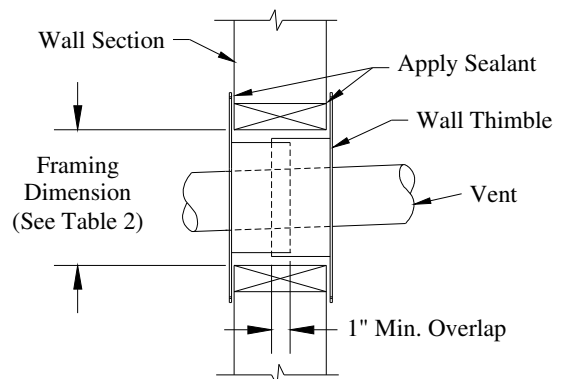

Fig 15. (Wall Thimble)

2. Select one half of the Wall Thimble and position it so the shield extends into the wall section.
3. From the opposite side of the wall, position the other half of the wall thimble so that the shield extends into the wall and engages with the other half of the Wall Thimble.
Note: The thimble shields must overlap a minimum of 1". If the wall is thicker than 6", the shields may be extended by using a piece of 6" Diameter galvanized pipe.
4. Apply silicone sealant to seal the trim plate to the wall surface.
5. Use 4 #10x1-1/4" wood screws to secure the Wall Thimble to the wall.
6. Route the vent through the opening in the Wall Thimble and seal the annular space between the vent and Thimble with silicone sealant.
7. The Wall Thimble Assembly may be painted to match the wall décor.

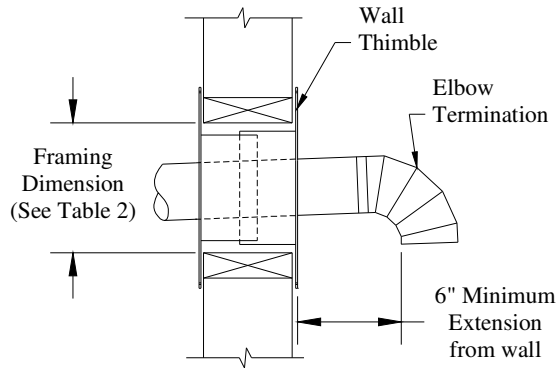

Fig 16. (Wall Thimble & Elbow Termination)

Horizontal Termination

The Horizontal Termination is used to terminate a horizontal vent system. There are several different Horizontal Termination styles available. These include the Mitered Termination Screen, an Elbow Termination and a Screen Termination. All Horizontal Terminations install the same way by connecting them to the vent pipe via standard Ring & Tab Connection method. The Horizontal Termination must terminate a minimum of 6" from the wall (See Fig. 16 & 17).

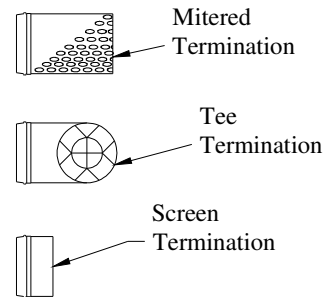

Fig 17. (Horizontal Terminations)

Appliance Connectors

Connect the SW vent system to the appliance flue collar as directed in the appliance manufacturer's instructions. If the appliance flue collar is not designed for direct connection to the SW vent system, a special appliance adapter may be required. See SW appliance adapter chart, the appliance manufacturer's instructions or contact us for recommended adapters.



Hart & Cooley, Inc. 616.656.8200 p
 5030 Corporate Exchange Blvd. SE 616.656.6399 f
 Grand Rapids, MI 49512
 info@hartcool.com
 www.hartandcooley.com